

# K-12

SEGMENT BROCHURE

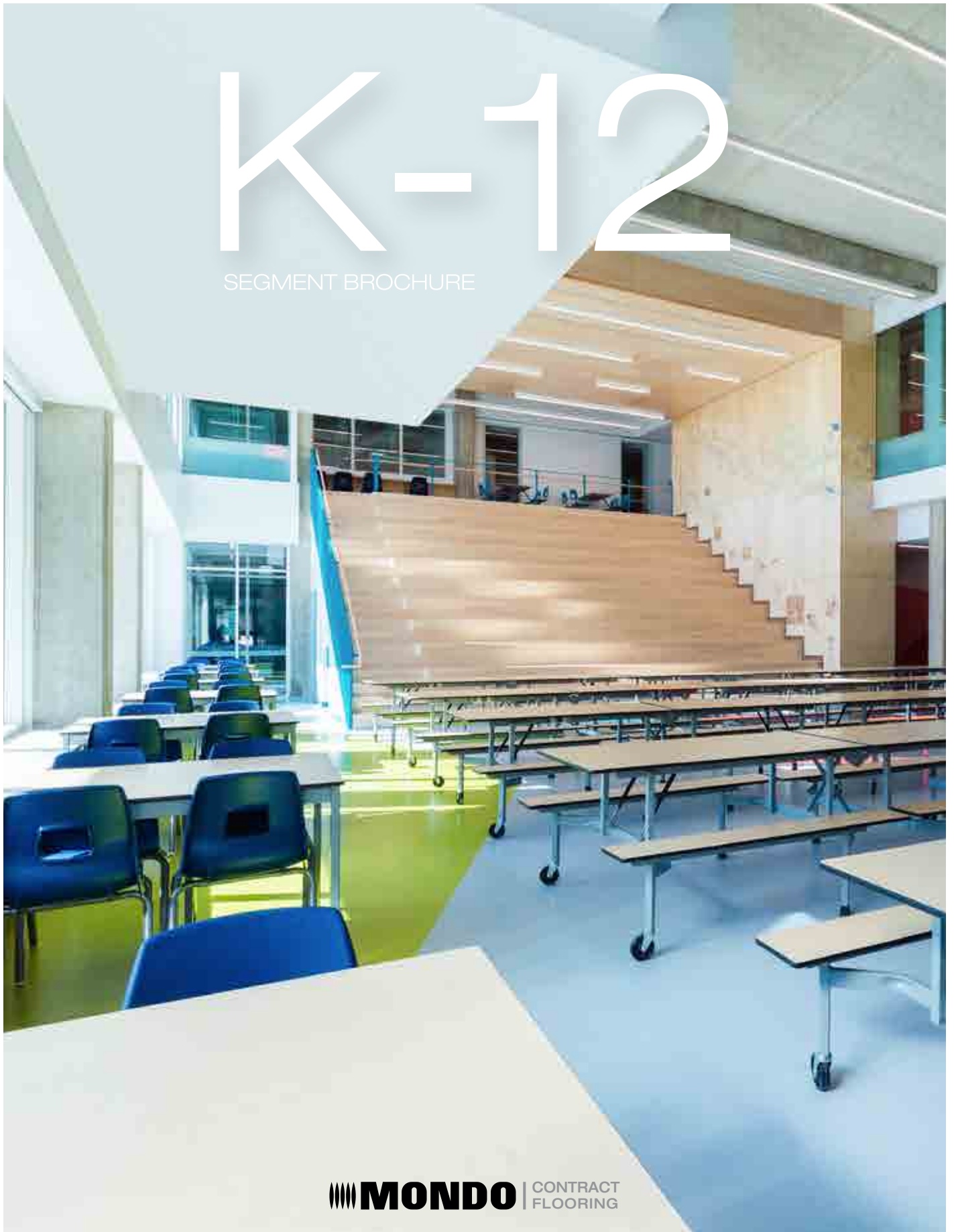

# MONDO RUBBER FLOORING

Rubber is able to express an emotion, transmit a taste for beauty and tell a story of excellence and enthusiasm. We seek practical and high-performance solutions characterized by an appearance that is able to interpret a contemporary vision of space. High durability, increased comfort, reduced noise and improved safety. You can expect your Mondo contract rubber flooring to enhance any space you desire.

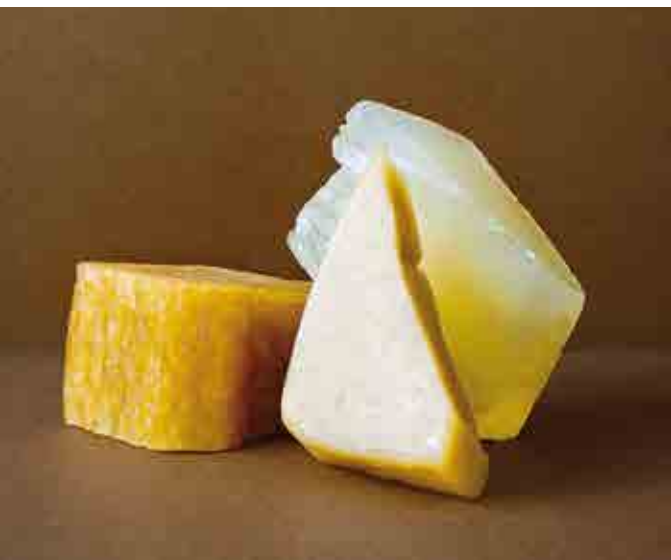

## **MONDO PREMIUM RUBBER FLOORING HELPS DESIGN A SUCCESSFUL LEARNING ENVIRONMENT.**

The natural elasticity of virgin rubber provides unparalleled comfort and acoustics while conserving outstanding wear resistance. None of our floors requires additional finishes, need only basic cleaning with neutral detergents, and have 30+ year lives, which serve to provide unmatched life cycle costs. All of our products are naturally bacteriostatic, have low VOC's and are environmentally-friendly throughout their entire life cycle.

### **HISTORY OF MONDO**

### **RESEARCH & DEVELOPMENT**

### **DUAL DUROMETER**

### **UNDERFOOT COMFORT**

### **ACOUSTICS**

### **MONDOSHIELD & MAINTENANCE**

### **SAFETY**

### **DURABILITY**

### **SUSTAINABILITY**

### **WARRANTY & COSTS**

### **CERTIFICATION**

### **PROJECTS**

### **REFERENCES**



# MONDO: A HISTORY OF RUBBER

## DECADES OF PERFORMANCE, GLOBALLY

Mondo has been a family-owned company since its beginnings in Gallo D'Alba, Italy, in 1948. Two entrepreneurial brothers, both barely out of the teens, Elio and Feruccio Stroppiana started working in the basement of the family home, enamored with the prospect of building their own business and armed with the fascination of using rubber as their primary raw materials.

Their first creation was a « Pallone Elastico », a sports ball made for a game played in the courtyards of the local villages. Their interests soon focused on larger initiatives, namely the creation of the first rubber flooring production line in 1955. Their commitment to excellence, their determination and leadership inspired generations of employees to build a company that has evolved into a diverse and adaptive multi-national entity.

*“A family-owned business since its founding in 1948, Mondo sells its products all over the world through Mondo-owned manufacturing companies in Italy, Luxembourg and Spain.”*

## A HISTORY OF EXCELLENCE

Mondo's global success has been built upon our investment in research and development, from the raw materials to our final products and including the equipment and processes that are necessary to meet the changing needs and expectations of our customers. Mondo acquired Artigo, a division of Pirelli, in 1992. Pirelli's advanced technology and design concepts coupled with Mondo's skills and experience made a formidable union. Artigo is the purveyor of the Mondo brand outside of North America.









# TECHNOLOGY & INNOVATION

## **SPORT TECHNOLOGY FOR CONTRACT FLOORING**

Following its purchase from Pirelli, Artigo collaborated with the Mondo Sport Research and Development team to incorporate Dual Durometer technology into contract products. The introduction of Dual Durometer construction allowed Mondo to elevate key performance characteristics essential for the education market, primarily that of comfort, acoustics, without sacrificing durability or useful life. Where other manufacturers are limited to simply altering maintenance protocols, thickness or composition of a coating Mondo looked to redevelop the product to create something completely unique.

Mondo is the global leader in the rubber flooring market, engineering quality surfaces to meet the highest standards in the industry. We manufacture rubber flooring that is durable, easy to maintain, hygienic, and environmentally responsible.

*Mondo's current line of Contract products is the direct result of research and development performed and perfected by our Sports Division. Mondo is the sole supplier of the 2020 Tokyo Olympic and Paralympic Games in athletic equipment and athletic track.*

## **PERFORMANCE THROUGH INNOVATION**

Mondo developed its Dual Durometer Technology through the collaboration of internal and external resources, including that of the Human Performance Lab at the University of Calgary. This innovation redefined the interaction between elite athletes and the surface on which they are competing. The ultimate goal being finding the perfect balance between comfort and performance. Mondo's track surfaces have now been the choice of the Summer Olympic Committee for the past 12 Olympic Games and have gathered over 260 world-records. Athletes of the highest levels train on Mondo track surfaces.



© Copyright Frank Döring

Frank Döring



# FEATURES FOR SCHOOLS

## MONDO CONTRACT FLOORING - FOR EACH AREA

- Entrances and Hallways
- Classrooms
- Cafeterias
- Libraries
- Multi-purpose rooms
- Auditoriums
- Labs
- Administrative offices
- Recreational Areas
- Locker Rooms

Whether you are in the market for sustainable materials to update aging education facilities or you are responsible for vetting best in class floor coverings for new education construction projects, Mondo Contract Flooring offers a wide array of premium flooring solutions for virtually all areas of your school.

As the world's leading premium rubber manufacturer, Mondo has been innovating with vulcanized rubber for over 70 years and has cultivated its delivery model around helping clients exceed project objectives within established timelines and budgets. We work directly with project teams and stakeholders to ensure complete satisfaction of the end user.

Mondo, 70 years of experience in high performance educational flooring.



# DUAL DUROMETER

## MONDO FLOORING - POWERED BY DUAL DUROMETER TECHNOLOGY

We engineered our unique Dual Durometer premium rubber flooring system based on market demands. Through the vulcanization process, Mondo is able to molecularly bond two layers of virgin rubber. Each of the two layers is designed to perform specific functions to create a high-performance floor that will enhance the students and teachers' experience.

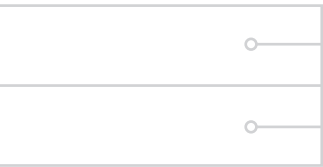

*The top surface is our homogeneous performance layer with its own set of design, safety and durability properties, including excellent slip resistance in wet and dry conditions.*

*The bottom layer contains sustainability and performance characteristics that allow for comfort underfoot, sound absorption and high rolling and static load resistance.*

MONDO DUAL DUROMETER	COMPETITOR
1.0 mm minimum performance layer.	0.2 to 0.3 mm decorative wear layer.
Maintains malleable physical properties over life span allowing for integral coving.	More difficult for integral coving and may need more expensive prefabricated cove which increases seams and cost.
Can use recycled content inside of bottom layer without changing durability of the product.	Not able to use recycled content unless entire product uses recycle materials, which may reduce performance.
Does not require waxes or sealers.	May require waxes or sealers or use of invasive and expensive diamond grit pads.
6' Sheet goods reduce seams and incidence of Infection control issues.	4' Sheet goods can increase incidence of seams by 20%, reduce overall aesthetics and reduces infection control.
15-year wear warranty. Engages after 0.0375 inch of loss.	15-year wear warranty. Engages after 0.575 inch loss.









# UNDERFOOT COMFORT

## BENEFITS - FOR TEACHERS AND STUDENTS

The proprietary technology of our Mondo Contract Flooring line elevates our product's performance. Our Italian engineers incorporated the best elements of our world record Olympic sport surfaces into a high performance education flooring solution. As a result, our flooring offers better comfort underfoot for teachers, students and staff while maintaining an excellent resistance to static and rolling loads such as desks and chairs. With its anti-fatigue property, our flooring helps to make all users more comfortable during their day by reducing leg and back pain from standing on hard surfaces.







## STUDENTS

When building an outstanding learning environment, comfort starts with the type of flooring selected. Students are the epicenter of all educational facilities and are a great example of how flooring can have a noticeable impact on learning and development. For example, hallways and classrooms comprised of a cold hard surface will only add to discomfort and increase lack of focus during long school days. In comparison, choosing a thicker, natural resilient surface will make these spaces that students traverse constantly during the day more comfortable and efficient.

## TEACHERS

Teachers are dedicated to the educational development of our children. They can be on their feet the entire day, lecturing, moving from class to class or engaging with their students in various activities. Increased comfort underfoot will lower the impact on legs and back and will subsequently reduce muscle fatigue. This will allow our teachers to completely focus on the next generation of creative minds with renewed energy and enthusiasm.

*The benefits of lower foot impact lead to less musculoskeletal fatigue, allowing teachers and students to go about their day safely and comfortably.*

Important feature for: ● ● ● ● ● ● ●



# ACOUSTIC COMFORT

Mondo's Dual Durometer technology also provides our flooring with a better acoustic absorption level. This will reduce the ambient noise level and will keep sounds from rebounding and traveling throughout hallways and classrooms. As high levels of noise are proven to increase stress levels and create distractions, an optimal learning environment would logically seek to control acoustics. One way to do so is selecting a flooring that will offer noise reducing efficiency. Mondo's standard 3mm products carry the highest level of sound absorption in the resilient industry: 14dB and up to 21dB when using our X-Elastic acoustical backing.



*A space with more intimate acoustics, where noise is not amplified or carried through hallways and classrooms will make the environment increasingly comfortable for all users.*

Important feature for: ● ● ● ● ● ● ●



### **FOR STUDENTS**

Acoustics in classrooms are paramount in terms of providing learning spaces where students are set to achieve academic success. Mondo Contract Flooring is engineered to reduce ambient noise of discussions, foot traffic and moving equipment in order to allow students to focus on their teacher and their studies. It participates in making the classrooms, auditoriums, students' spaces and hallways less institutional and more welcoming. Facilities where students are more comfortable and calm will give them their best chance at a positive experience and academic achievements.

### **FOR TEACHERS AND STAFF**

Improving working conditions for teachers, administrative staff and other school facility workers is also vital. Some resilient and hard surfaces can make a space seem cavernous and are prone to reverberations. Increased noise levels and ambient sound also inhibit concentration levels for teachers and can be the root cause for distraction and stress. The right choice of flooring will create a better environment and can increase overall work satisfaction.



# INCREASED SAFETY

## INFECTION CONTROL

The COVID pandemic has added a new and very serious concern about the health and safety of our children at school. Fortunately, Mondo Contract Flooring, due to its raw materials and manufacturing process, is naturally bacteriostatic and is classified by the CDC as a non-critical surface when speaking of infection control. Non-critical surfaces should only require routine cleaning with a neutral cleaner. Disinfection can be performed as necessary with a neutral disinfectant. In addition to its bacteriostatic properties, Mondo Contract Flooring is dimensionally stable and does not require heat or cold welding of its seams. Our product will not shrink with time like some sheet vinyls or VCT products. Given that Mondo's sheet goods are an industry leading 6'2" wide the chances of bacteria growth inside of an open seam are very remote.

*For more information on disinfection, please consult our white paper available on our website.*



## FIRE RATING

Another standard for safety is the fire rating. Class 1 fire rating is the requested level of resistance to fire and to flame spread in most education facility. Mondo flooring is Class 1 fire rated as per ASTM E648.

Important feature for: ● ● ● ● ● ● ● ● ● ●



## SLIP RESISTANCE

Spaces where traffic is high and spills are frequent call for a flooring that has the required standard for slip resistance: ADA 302 Floor and ground surfaces. Chemistry classrooms, STEM labs and cafeterias are prone to hazards and accidents. A flooring with slip resistance properties can help to avoid slips and falls and improve children and staff's safety throughout the school. Mondo's rubber flooring provides outstanding co-efficient of friction in both dry and wet conditions as it complies with ADA 302 Floor and ground surfaces.



## WAYFINDING

Designing a wayfinding process is important for the students' journey. A child's sense of competence is encouraged by making spaces easy to find, identify, and use without asking for help. A well thought-out pattern for circulation will improve flow efficiency while reducing the risks of accidents. Embedding wayfinding features in the flooring creates visual pathways to show direction of traffic and circulation areas. Incorporating school colors, mascots and mottos help to create a theme for an uplifting environment bolstering school pride.



# MONDOSHIELD & MAINTENANCE

## MONDOSHIELD

Mondo's smooth commercial rubber product lines, Granito, Harmoni, Kayar, Massetto, Natura, Uni and Dharma are manufactured with Mondoshield. Mondoshield is a factory applied surface treatment cured by ultraviolet (UV) light, which produces a low-gloss finish and requires no special care. In fact, Mondoshield helps to lower the necessary maintenance while increasing its durability.

## EASE OF MAINTENANCE

Our flooring's maintenance requirements are simple and straightforward. Once it is installed there is no added preparation or maintenance, just mop and go. It does not require stripping, sealants or floor finishes and can be maintained using certified green cleaners and/or ionized/electrically converted water. Our maintenance regimen does not call for expensive and invasive accessories such as diamond pads. As our recommended maintenance is less complex, it is easy to train maintenance personnel or to adapt cleaning procedures to the school's sanitation standards. No more stripping and waxing lead to the lowest cost of maintenance of resilient flooring.

## FACILITY DOWNTIME

The inherent properties of Mondo rubber flooring provide for a dense, nonporous surface that naturally repels dirt and bacteria. It allows maintenance teams the opportunity to institute an easy-to-follow cleaning protocol that does not require heavy cleaning equipment, the use of harsh chemicals or prolonged facility downtime. Faster maintenance means more usage of your facility, for after-school activities, community events or continued education.

*As Mondo rubber flooring's maintenance and Mondoshield work together, your facility will both appear cleaner and actively improve the sanitary condition of your facility.*

Important feature for: ● ● ● ● ● ● ●





# MONDOSHIELD & CHEMICALS

## INCREASED RESISTANCE TO CHEMICALS

As school's laboratories and STEM labs are areas of rapid activity and numerous manipulations by students, it is inevitable that spills will occur. Choosing a flooring that resists chemicals means fewer renovations and heavy maintenance. It also increases safety by reducing hazards from damaged flooring. Providing students with a safe and resistant areas to learn encourages them to experiment and develop their science knowledge.

*\*A full list of chemicals tested is available at the end of this brochure.*



Important feature for: ● ● ● ● ● ●





# INCREASED DURABILITY

## BENEFITS - MADE TO LAST

With proper maintenance and care, Mondo's premium rubber flooring has a lifespan that will surpass 30 years. We diligently use only the finest raw materials in the industry and are constantly improving manufacturing equipment, protocols and processes. The result of your investment in Mondo will stand for generations to come.

The age of our references is a testament to our durability and quality. Iconic projects such as the CHUQ Hospital and the Notre-Dame Basilica both receive millions of staff and visitors each year and are still in place several decades after their installation. Our extensive education reference list further displays our knowledge of this market's needs and requirements.

Our Dual Durometer construction increases the longevity of our products as it allows us to modify our performance layer without compromising other key characteristics such as comfort and acoustics. Our performance layer is therefore thicker than most other resilient flooring. Perfect for withstanding heavy static and rolling loads common in the education environment, it is also well adapted to high traffic areas where the intensive use tends to wear down other types of flooring; your flooring will not only last, but will maintain its appearance. Mondo also engineers its adhesives and installations solutions to accommodate the rigors of innovative equipment, chairs and tables.

<p><b>Harmoni 3mm - smooth surface</b> Full depth multicolored granules in performance layer.</p>  <p>1mm* 2mm</p> <p><b>Mondo Contract Flooring</b> <i>*Approximate thickness of the Performance Layer</i></p>	<p><b>3mm - smooth surface</b> Decorative wear layer with multicolored granules.</p>  <p>0.2mm* 2.8mm</p> <p><b>Other resilient flooring</b> <i>*Approximate thickness of the Wear Layer</i></p>
--	---

Important feature for: ● ● ● ● ● ●

**CHUQ | QUEBEC CITY, CANADA | 2004**

*In 2006, the facility added a new emergency unit. This project was subject to intensive research and consultation. Our flooring was chosen and has graciously endured thousands of steps every day, the rigorous maintenance ongoing in healthcare installations, along with every spills and liquids it has come in contact with.*



**NOTRE-DAME BASILICA | MONTREAL, QUEBEC | 1995**

*The Notre-Dame Basilica is a historic building situated in the heart of Old-Montreal. The work on the (then) Notre-Dame church began in 1672. Renovations and restorations have since maintained the historic building, and a Mondo flooring was installed to welcome the footsteps of a million visitors and parishioners each year.*





# SUSTAINABILITY

## FOR A BETTER WORLD - MONDO'S SUSTAINABILITY COMMITMENT

Mondo Contract Flooring meets the requirements for HH Safer Chemicals Challenge Level 4 commitment. Our rubber flooring does not contain polyvinyl chloride (PVC), phthalates (including DEHP), Perfluorinated compounds (PFCs), heavy metals (including mercury), formaldehyde, isocyanates, flame-retardants, antimicrobial agents, or any red listed ingredients (LBC Red List).

Mondo is committed to achieving the highest standards that respect both our ecosystem and the society around us. Strict controls on production and the prestigious international environmental certifications of our products are proof of our commitment to the environment. In 2010, we invested in the installation of 4,173 solar panels on our factory roof, reducing our CO2 emissions by about 14,440 tons annually. And as of 2019, we can certify that the electricity used by our Italian manufacturing plant is 100% generated from renewable sources: wind, sun and water.

## CERTIFICATIONS

Mondo rubber flooring also significantly contributes to LEED credits, BREEAM certification, as well as compliance to many other sustainability programs. We carried out a thorough study on the Analysis of the life cycle of our products through the Environmental Product Declaration (EPD) and opted for further transparency by completing Health Product Declarations (HPD).

*Note that Mondo uses premium virgin rubber within its formulations and does not rely primarily on recycled SBR rubber (car tires) which have been associated to carcinogen and fire-related concerns.*



ISO  
9000

ISO  
14001







## INDOOR AIR QUALITY

VOCs (volatile organic compounds) are common in indoor environments with levels ranging from two to a thousand times higher than outdoors. Chemical emissions are the most harmful to Indoor Air Quality (IAQ) as they can contribute to a wide range of health issues. Babies and children, along with anyone who has an immune system deficiency or people living with various disabilities can be especially susceptible to adverse effects from VOCs. Those should be minimized as much as possible in the education facilities, where children are spending their days. Several certifications and standards exist to quantify the amount of VOCs emitted. The California standard C03150 is a benchmark for indoor air quality in North America, limiting 35 VOCs. The industry standard for resilient flooring is FloorScore, which is industry-owned and tests for the same 35 VOC as CA01350. All our flooring are GREENGUARD Gold certified, the highest-level third party VOC testing certification available for resilient flooring. GREENGUARD Gold tests for over 365 VOCs, a guarantee that the material will contribute to fewer emissions and a better indoor air quality.

Important feature for: ● ● ● ● ● ● ● ● ● ●



# WARRANTY & MATERIAL COSTS

## MONDO WARRANTY

Mondo is proud to offer a 15-year wear warranty on all our contract flooring materials. As our history demonstrates, we manufacture a quality product that becomes a long-term asset in education environments.

We understand the reality of funding for renovations and construction of facilities, balancing the required features and standards against capital and operational costs. All, of course, without compromising on the quality of education. Mondo's premium line of rubber flooring can save money in both capital investment and long-term operational costs that can range into the hundreds of thousands of dollars making it a long-term, financially responsible decision.

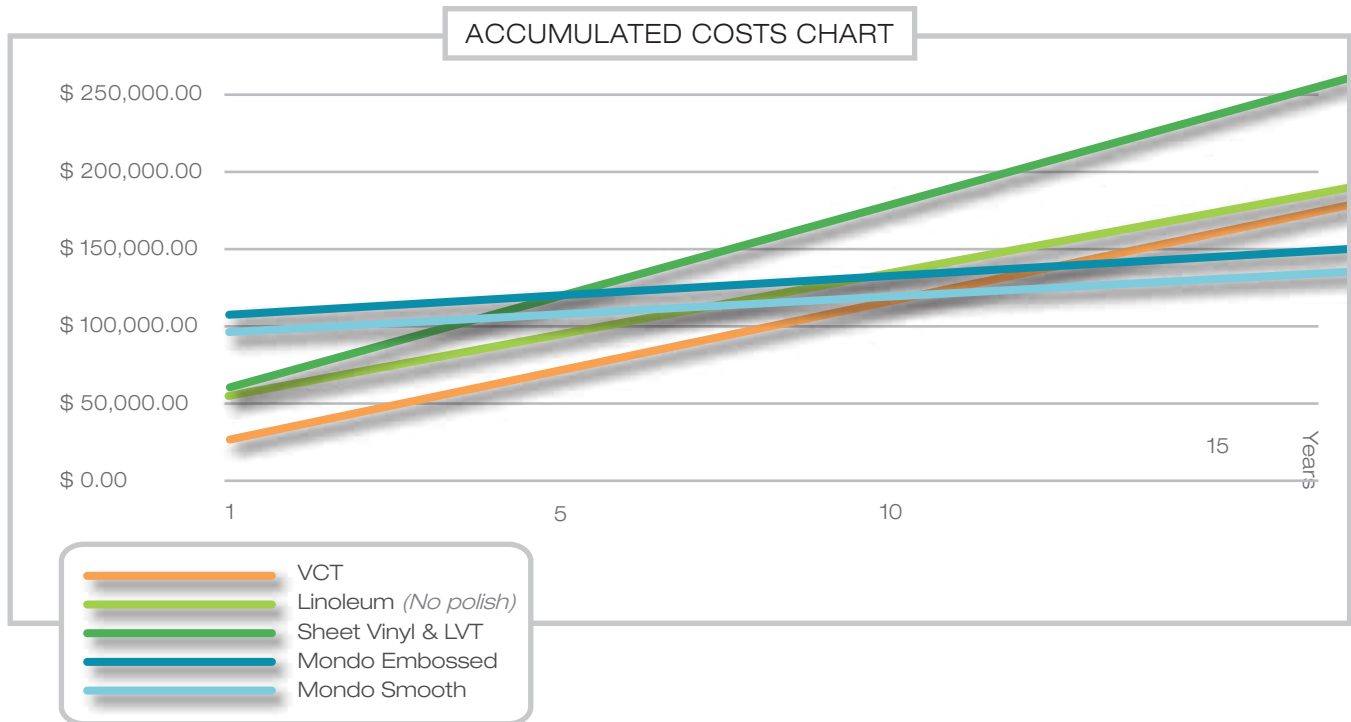

*\*Study based on labor times from the International Sanitary Supply Association (ISSA)'s publication "612 Cleaning Times".*



# CERTIFIED INSTALLATION

## A COMPETENT TEAM

Contractors and installers are strong contributors to the success of various flooring installations. How easily a product seams together, speed of installation and amount of product waste are all-important to review with the flooring contractor. Mondo has developed long-term relationships with qualified professionals who will ensure that installation procedures are adhered to for the best possible end-result.

## INSTALLATION CERTIFICATION PROGRAM

We take pride in our Contract Installation Training & Certification programs, which have been completed by hundreds of professionals. Our training regimen pushes the limits of candidates' knowledge and installation proficiency. Attendees must pass practical and theoretical tests in order to gain their title of Mondo Master Mechanic. They gain hands-on, product-specific experience and get to exchange with other professionals in their trade to become proficient Mondo installers.

We maintain records of installers' credentials and hold several certification classes each year. Therefore, Mondo is able to provide references, or training when necessary in order to help ensure a high-quality installation for every project.



# Case Study

STOCKTON UNIFIED SCHOOL DISTRICT | STOCKTON, CALIFORNIA



## K-12 TO HIGH SCHOOLS: A NEED FOR CONSTANT RENOVATIONS.

The Stockton Unified School District, in Stockton California, assembles 54 k-12 and high schools facilities. 4,000 teachers and staff are tasked with the education and care of about 40,000 students. When doing renovations and new construction projects, they have been choosing Mondo flooring for years.

School renovations have the responsibility to improve students' environment to set them up for greater success. They are a chance for schools planners to retrofit aging but durable buildings into updated teaching facilities. With the number of classrooms and spaces that are in need of modernization and the funding required to do so, the topic of schools renovation has gained nationwide focus.

Well thought-out renovation projects will incorporate efficient design improvements and appropriate materials to allow for high return on investment and

better school ratings. Several elements must be considered to support an active learning environment, including ergonomic furniture, graphics, school colors, improved lighting and acoustics; all the while considering the current technology used in classrooms and somehow planning for future technological advances. Overall, renovations mean a lot of work but also a great opportunity.

## EFFICIENT AND INSPIRING DESIGN.

Effective and well thought-out flooring design have a beneficial effect on schools. The use of colors and patterns are widely used to include wayfinding cues. Stockton USD chose Mondo Contract Flooring as it allowed them to create borders and areas within the flooring. Those wayfinding cues further encourages students' sense of self-sufficiency by giving them the tools to make their way around the school safely and confidently.



**Walton Special Center** – Walton Special Center offers special education services for eligible students with severe disabilities from the ages of 3 to 22. Support services including psychological, speech and language, aquatics, physical therapy and feeding therapy. As their students need various types of support, the flooring needs to be versatile, comfortable, safe and highly performing. From 2009 to 2011, nearly 20,000 square feet of Terranova were installed as part of renovation projects. Mondo was chosen for its ease of maintenance and fitting color options.



**Stagg High School** – Stagg High School strives to prepare students for college and/or postsecondary careers success in the 21st Century. The project at Stagg High school looked at renovating and upgrading existing classrooms as well as the renovation of the school's kitchen. As classrooms are busy every day, the flooring needs to be particularly durable while participating in creating a better learning environment. As a particularly durable surface, Zeus was chosen to cover over 7,000 square feet of classrooms. Mondo was selected as it became the district standard for its maintenance, looks and acoustic value.

*It is important to find a flooring option that could address issues such as acoustics, maintenance and underfoot comfort for staff and children.*

#### **MATERIALS: OPPORTUNITIES & CHOICES.**

Whether the project is about updating a building or creating a new facility, choosing specific guidelines to fit the school's needs will help opting for the right materials. For Stagg and Edison High Schools and Walton Special Center, Stockton USD's desire to improve classroom acoustics lead to a search for sound absorbing materials such as Zeus and Terranova. Those products became a standard for the district, as they require minimal maintenance and, with their GREENGUARD Gold certification, contribute to the facility's indoor air quality. Wanting to create a continuous design with wayfinding elements, they also needed flooring that offered a color range suitable to their vision. As Mondo offers high performance features across our whole range and color palette, the choice was clear.

#### **MAINTENANCE: SAVE ON THE LONG-TERM.**

Above the cost of acquisition and installation, a long-term cost that should be considered is the cost of maintaining the material selected. Mondo rubber flooring has been installed throughout several schools in the Stockton school district for its straightforward and cost-effective maintenance. As there is no stripping, waxing or pad system involved in the maintenance, investing in our rubber flooring allows the school district to plan for lower annual maintenance costs and a cleaner looking school.





### Edison High School

The High School's development took about 5 years. The project involve the creation of multiple new buildings to upgrade the existing campus. Zeus and Terranova were installed in classrooms, offices and a snack bar, areas where acoustics and maintenance can be a challenge. Mondo was chosen as a durable and performing flooring that will help in creating the optimal environment to allow students to achieve their full potential.

### Stagg High School

**FLOORING:** Zeus Z628, Z638 & Z639

**TOTAL SQ. FT.:** 12,507 sq. ft.

**DATE:** 2017-2018

### Walton Special Center – Special Needs

**FLOORING:** Terranoa 448 & 449

**TOTAL SQ. FT.:** 19,900 sq. ft.

**DATE:** 2009-2011

### Edison High School

**FLOORING:** Zeus Z628, Z636 & Terranova

**TOTAL SQ. FT.:** 91,515 sq. ft.

**DATE:** 2011-2018

